

9600 Aldrich Avenue South  
Minneapolis, Minnesota 55420 USA  
Telephone 612-884-4051  
telex 6879045  
Fax 612-884-0043

## TO HOLDERS OF 5x5® PRO III MANUAL

REVISION NO. 5 DATED APRIL, 1995

### HIGHLIGHTS

Pages which have been revised are outlined below together with the highlights of each change.

<b>Page(s)</b>	<b>Description of Change</b>
All	Non-technical style and format changes.
All	Added -100 series 5x5 ProIII Headsets. Each -100 series headset corresponds to a previous version. For example the 64000-100 headset corresponds to the previous 64000-000 headset; the 64000-105 headset corresponds to the previous 64000-005 headset and so forth. The only difference between the old and new version of each headset is the microphone boom (and the headband/eyeglass clip, since each version has the catalog number imprinted on the clip). The new microphone boom is form-fit-and-function compatible with the old, but has an improved grill design.

HIGHLIGHTS

PAGE 1 OF 1

## MODEL 5x5<sup>®</sup> PRO III SERIES HEADSETS

MAINTENANCE AND OVERHAUL MANUAL  
FOR  
HEADSET  
MODEL 5x5<sup>®</sup> PRO III  
TELEX PART NO. 64000-000 and 64000-100  
TELEX PART NO. 64000-001 and 64000-101  
TELEX PART NO. 64000-002 and 64000-102  
TELEX PART NO. 64000-003 and 6400-103

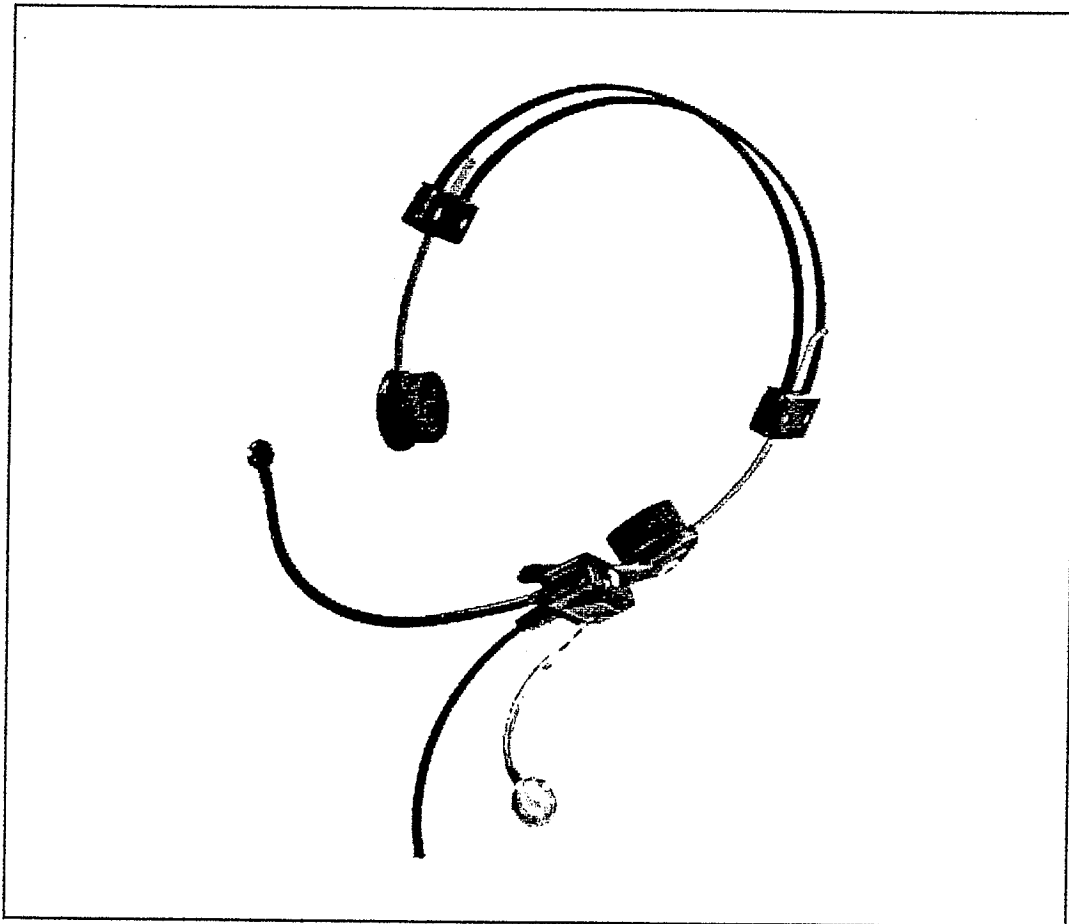

MODEL 5x5<sup>®</sup> PRO III

Figure 1.

## **ATA 23-50-05**

## **ATA 23-50-05**

MODEL 5x5<sup>®</sup> PRO III SERIES HEADSETS

## RECORD OF REVISION

REV. NO.	REVISION DATE	INSERTION DATE	PAGES EFFECTED	BY
1	5/86	5/86	All	Telex
2	6/87	6/87	Title, i, ii, 3, 7	Telex
3	8/89	8/89	Title, i, ii, 6, 7 and 9	Telex
4	8/92	8/92	All	Telex
5	4/95	4/95	All	Telex

MODEL 5x5<sup>®</sup> PRO III SERIES HEADSETS

## LIST OF EFFECTIVE PAGES

SUBJECT	PAGE(S)	DATE
Title Page	—	April, 1995
Record of Revisions	i	April, 1995
List of Effective Pages	ii	April, 1995
Table of Contents	iii	April, 1995
Description and Operation	1-3	April, 1995
Disassembly/Assembly	4-8	April, 1995
Electrical Adjustments	9-10	April, 1995
Wiring Diagrams	11	April, 1995
Troubleshooting Chart	12	April, 1995

**23-50-05**

## MODEL 5x5® PRO III SERIES HEADSETS

### TABLE OF CONTENTS

SECTION AND PARAGRAPH	PAGE
<b>1. Description and Operation</b>	
A. General . . . . .	1
B. Microphone . . . . .	1
C. Receiver . . . . .	1
D. Amplifier . . . . .	1
E. Cords . . . . .	1
F. Operating Specifications . . . . .	3
G. Operating Procedure . . . . .	3
<b>2. Disassembly/Assembly</b>	
A. General . . . . .	4
B. Removal of Cordage, Receiver, and Boom Microphone Assemblies . . . . .	4
C. Removal of Amplifier Assembly . . . . .	5
D. Headband Disassembly . . . . .	5
E. Headset Assembly Parts Lists . . . . .	7
<b>3. Electrical Adjustments</b>	
A. Microphone/Amplifier Sensitivity Check . . . . .	9
B. Microphone Sensitivity Attenuation (Units with Hybrid Amplifier Assembly) . . . . .	9
C. Microphone Sensitivity Attenuation . . . . . (Units with Adjustment Potentiometer and Access Hole)	10
<b>4. Troubleshooting Chart . . . . .</b>	12

### LIST OF ILLUSTRATIONS

FIGURE NO.	DESCRIPTION	PAGE
Figure 1	Model 5x5® Pro III Headset . . . . .	Cover
Figure 2	Component Identification . . . . .	2
Figure 3	Amplifier Assembly Removal . . . . .	5
Figure 4	Headset - Exploded View . . . . .	6
Figure 5	Loading Network . . . . .	9
Figure 6	Wiring Diagrams . . . . .	11

**MODEL 5x5® PRO III SERIES HEADSETS****1. DESCRIPTION AND OPERATION****A. General**

The Telex 5x5® Pro III Series is a family of lightweight aircraft communication headsets. The headsets consist of a Headband Assembly, and a Receiver/Amplifier Assembly contained in a single housing with an attached Boom Microphone Assembly, eartip, and cord(s). The Receiver/Amplifier Housing with attachments may be removed from the Headband Assembly and clipped to eyeglasses using the Headband/Eyeglass Clip. Figure 2 shows an outline view and major component identification. The headsets are approved for aircraft use under FAA TSO C57 and C58.

**B. Microphone**

The boom-mounted, miniature, noise-canceling electret microphone element provides for maximum intelligibility and minimum background noise pickup. The boom is completely adjustable for optimum microphone positioning by means of the headband sliders and 360 degree rotative pivot arm. Additionally the boom can be swiveled 180 degrees side-to-side.

**C. Receiver**

Sound from the balanced-armature receiver element is fed to the ear through a vinyl tube terminating in a plastic eartip. The eartip can be fitted into the ear to block out ambient noise, or it can be adjusted to "float" a fractional distance from the ear. A custom earmold may also be used, providing the best comfort.

**D. Amplifier**

The amplifier is designed for 8-30 Vdc operation. It accepts input signals from the boom-mounted microphone and provides an output signal level which is comparable to the output of typical carbon-type microphones.

**E. Cords**

- (1) The -000, -001, -100, and -101 headsets have Y-type cord assemblies. These cords have a 3-conductor PJ068 or equivalent plug for microphone output and a 2-conductor PJ055B or equivalent plug for eartip receiver input. The cord for the -001 and -101 headsets has a built-in attenuator (approximately 4 dB) for the eartip receiver input. The cord for the -000 and -100 headsets has no attenuator.
- (2) The -002 and -102 headsets have a single cord terminated with a 3-conductor PJ068 or equivalent plug for both microphone output and eartip receiver input. This cord has a built-in attenuator (approximately 4 dB) for the eartip receiver input.
- (3) The -003 and -103 headsets have a single cord terminated with a 3-conductor PJ051 or equivalent plug for microphone output and eartip receiver input. This cord does not have a built-in attenuator.

## MODEL 5x5® PRO III SERIES HEADSETS

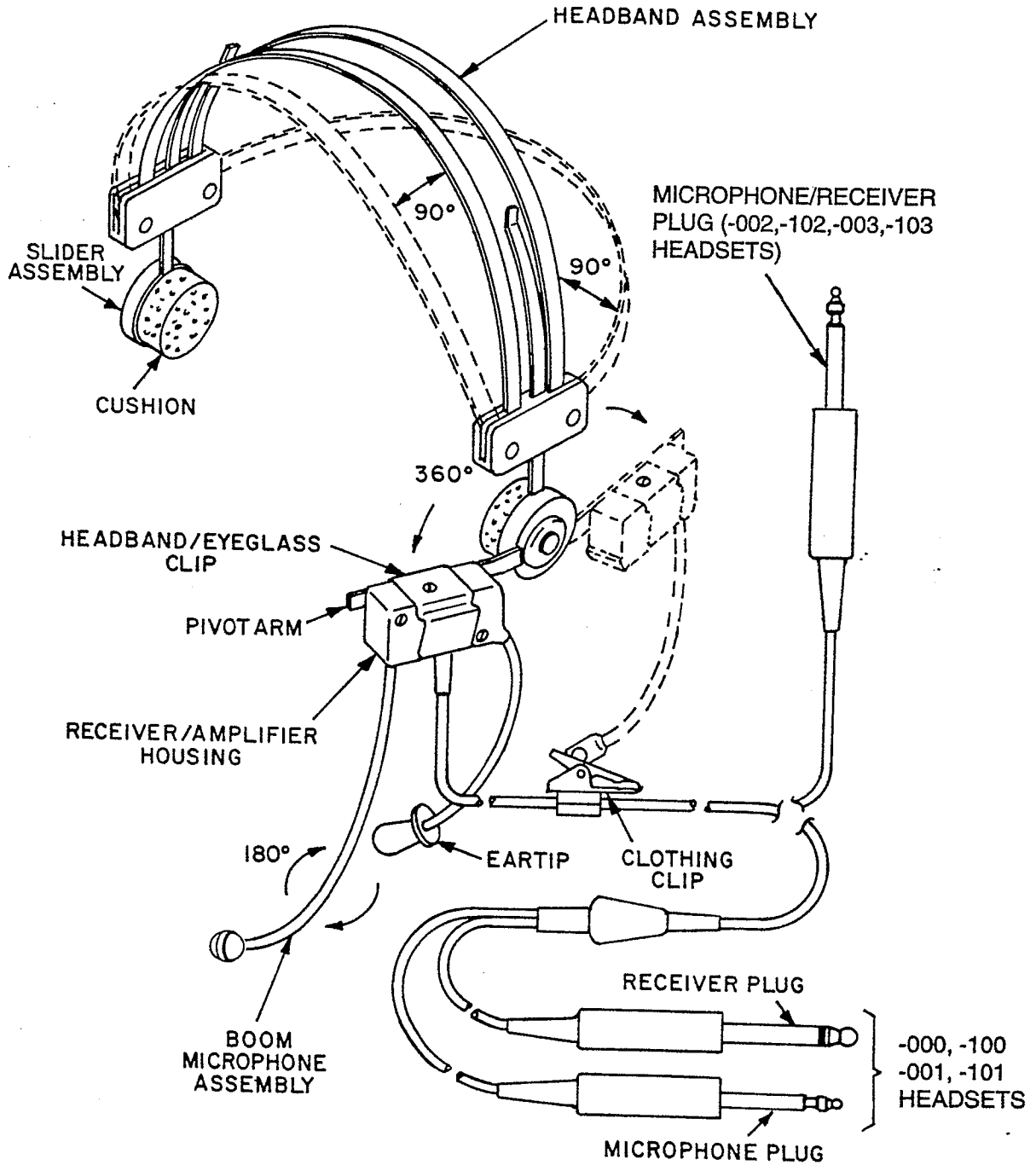

COMPONENT IDENTIFICATION  
FIGURE 2

23-50-05

## MODEL 5x5® PRO III SERIES HEADSETS

### F. Operating Specifications

Manufacturer	Telex Communications, Inc.
Model No.	5x5® Pro III
Part Nos.	64000-000 64000-001 64000-002 64000-003
Weight	4.4 oz (125 g)
Receiver Sensitivity	
64000-000, -100, -003, -103	119 ± 4 dB re: 0.0002 dynes/cm <sup>2</sup> for 1 mW at 1 kHz
64000-001, -101, -002, -102	109 ± 4 dB SPL re: 0.00002 dynes/cm <sup>2</sup> for 1 mW at 1 kHz
Receiver Impedance	600 ohms
Receiver Frequency Response	100-3000 Hz
Microphone Sensitivity	
64000-000, -100, -002, -102, -003, -103	-48 ± 2 dB ref: 1 V/μbar at 1 kHz, 12 Vdc, 150-ohm load
64000-001, -101	-46 ± 2 dB ref: 1 V/μbar at 1 kHz, 12 Vdc, 150-ohm load
Microphone Impedance	Matches 50-600 ohm inputs
Microphone Frequency Response	300-5,000 Hz
Cord Length	
64000-000, -100	7 feet (2.1 m)
64000-001, -101	6 feet (1.8 m)
64000-002, -102	6.75 feet (2.06 m)
64000-003, -103	5.5 feet (1.68 m)
Color	Black
Operating Voltage	8-30 Vdc

T1452, H

### G. Operating Procedure

To use the Model 5x5® Pro III Headsets, insert the plug(s) into the respective microphone and/or receiver jacks. Adjust the headband and boom microphone assembly for desired head comfort. Position the plastic eartip in the ear for comfortable ear penetration. Place the microphone as close as possible to the mouth. The headset is now ready to transmit/receive. If microphone/amplifier sensitivity attenuation is required, perform the procedure described in paragraph 3B, page 9.



**MODEL 5x5<sup>®</sup> PRO III SERIES HEADSETS****2. DISASSEMBLY/ASSEMBLY****A. General**

Disassemble the headset in accordance with the exploded view in figure 4 and parts lists on pages 7 and 8. Reassembly is simply a reversal of the disassembly process and is not discussed separately. In some instances notes to aid reassembly are inserted with the disassembly information.

**NOTE**

To prevent the loss or temporary misplacement of small parts, (e.g. screws, nuts, etc.) during the disassembly process, place them in a container suitable for this purpose.

**B. Removal of Cordage, Receiver, and Boom Microphone Assemblies**

- (1) Unclip the Receiver/Amplifier Housing from the Headpad and Pivot Arm Assembly (17).
- (2) Remove the phillips-head screw (1) securing the Headband/Eyeglass Clip (3) to the Receiver/Amplifier Housing. On the -001 and -101 headsets only, remove lockwasher (2). This lockwasher is not used on the other headsets.

**CAUTION**

To prevent the Cordage, Receiver, and Boom Microphone elements from falling out when the Receiver/Amplifier top and bottom housings are separated, perform step 3 with the housing resting on a work surface. If these elements are allowed to fall, their weight alone may be sufficient to break their interconnecting wires.

- (3) Remove the three binding head screws (4) and threaded sleeves (5). Carefully separate the top Receiver/Amplifier housing (13) from the bottom portion (14). Remove the square nut (6).

**NOTE**

Care must be exercised when separating the top and bottom housings to prevent the square nut from inadvertently falling out and becoming lost.

- (4) The Cordage (11), Receiver Assembly (7), and Boom Microphone Assembly (9) are now accessible for removal.

**CAUTION**

Do not use a soldering iron rated above 25 watts.

To facilitate reassembly, prior to disconnecting lead wires, first record each by color and termination.

### MODEL 5x5® PRO III SERIES HEADSETS

#### C. Removal of Amplifier Assembly

##### NOTE

Do not remove the Amplifier Assembly unless it has definitely been determined that replacement is absolutely necessary.

- (1) Follow disassembly sequence as previously described.
- (2) Record the lead wires soldered to the Amplifier Assembly (figure 4, 12) by color and point of origin. Disconnect lead wires.
- (3) Using a small-tip flat-blade screwdriver, remove amplifier by slowly applying gentle pressure downward as illustrated in figure 3.
- (4) Using a suitable bonding adhesive, such as Fullers 961 cement, insert replacement amplifier board into housing (13).

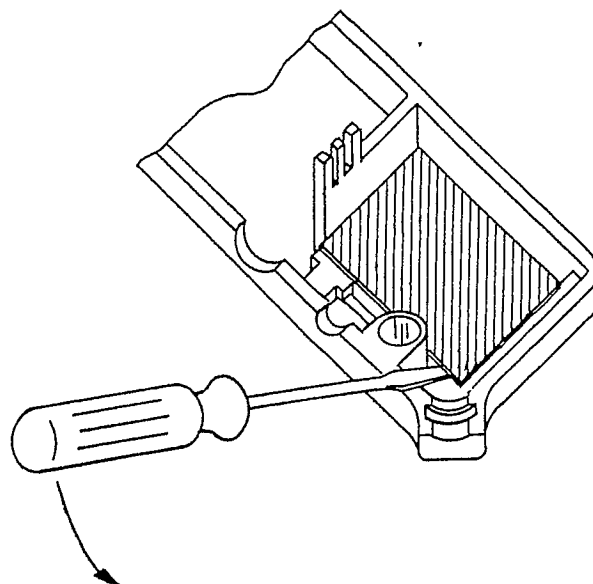

**HYBRID AMPLIFIER ASSEMBLY REMOVAL  
FIGURE 3**

##### CAUTION

Soldering required in step 5 must be done with a pencil-tip iron rated at 25 watts or less, using SN62 silver bearing solder. Failure to comply will result in permanent damage to the amplifier.

- (5) Resolder lead wires to replacement Amplifier Assembly. (Reference figures 6a-6d for appropriate wiring diagram.)

#### D. Headband Disassembly

##### NOTE

The following procedure applies to the Headband Assembly for the -001 and -101 headsets only. The Headband Assemblies for the other headsets are not serviceable and should be replaced as a unit; however, the cushions (figure 4, item 16) on all versions are replaceable.

- (1) Remove the Receiver/Amplifier Housing from the Headpad and Pivot Arm Assembly (17).
- (2) Grasp the Headband Spring Retainer Housings (24) between thumb and index finger and remove the two screws (19), lock washers (21), and hex nuts (20).
- (3) Holding the Headband Spring Retainer 2 to 3 inches above the working surface, separate the two halves.

##### NOTE

When reassembling, observe the following:

- (a) The serrated sides of the nylon washers (22) must face the Headband Spring Assembly (25).
- (b) Reinstall the Glider (23) with the concave side toward the outer Headband Spring Retainer Housing.

## 23-50-05

## MODEL 5x5® PRO III SERIES HEADSETS

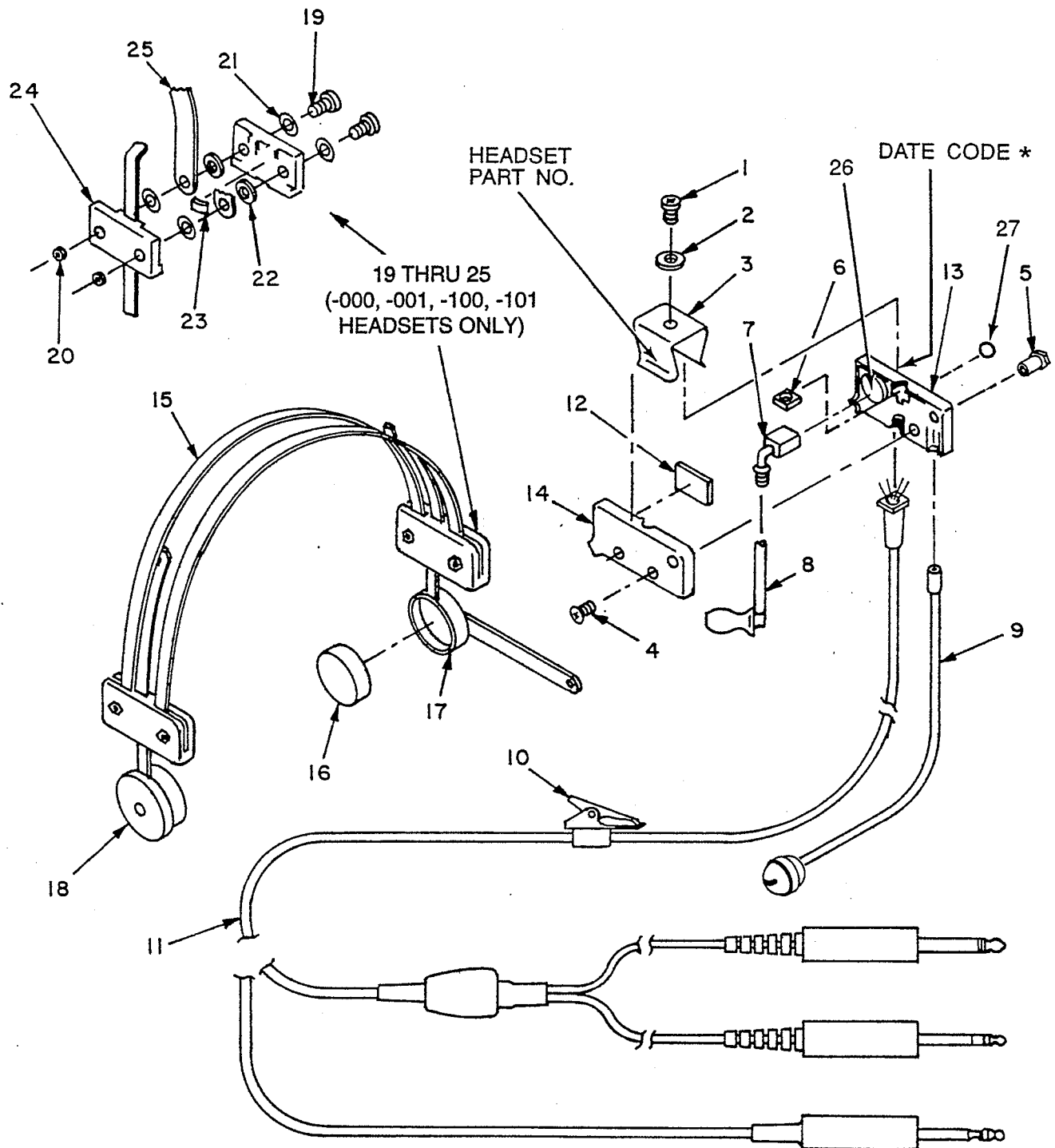

\* First two digits of date code are year of manufacture;  
last two digits are week of manufacture.

HEADSET - EXPLODED VIEW  
FIGURE 4

### 23-50-05

## MODEL 5x5® PRO III SERIES HEADSETS

### E. Headset Assembly Parts Lists (Figure 4)

64000-000, -001, -002, and -003 Headsets (See following page for other headsets.)

Item	Part No.	Description	Quantity, 64000-			
			000	001	002	003
1	51845-037	Screw, No. 4-40 x 3/16	1	1	1	1
2	50014-002	Washer, Lock	-	1	-	-
3	64001-001	Clip, Headband/Eyeglass	1	-	-	-
	64001-002	Clip, Headband/Eyeglass	-	1	-	-
	64001-005	Clip, Headband/Eyeglass	-	-	1	-
	64001-007	Clip, Headband/Eyeglass	-	-	-	1
4	56016-004	Screw, No. 0-80 x 3/16	3	3	3	3
5	63096-000	Sleeve, Threaded	3	3	3	3
6	53850-000	Nut, Square, No. 4-40	1	1	1	1
7	63977-000	Receiver Assembly	1	-	1	1
	63977-001	Receiver Assembly	-	1	-	-
8	35629-009	Eartip Assembly	1	1	1	1
9	63983-005	Microphone Assembly, Boom	1	-	1	1
	63983-006	Microphone Assembly, Boom	-	1	-	-
10	63097-002	Clip Assembly, Clothing	1	2	1	1
11	70413-001	Y Cord Assembly	1	-	-	-
	70413-000	Y Cord Assembly	-	1	-	-
	64249-000	Cord Assembly	-	-	1	-
	63988-016	Cord Assembly	-	-	-	1
12	600019-000	Amplifier Assembly	1	1	1	1
13	63976-007	Housing, Receiver/Amplifier, Top	1	1	-	-
	63976-006	Housing, Receiver/Amplifier, Top	-	-	1	1
14	63975-002	Housing, Receiver/Amplifier, Bottom	-	-	1	1
	63975-004	Housing, Receiver/Amplifier, Bottom	1	1	-	-
15*	63993-001	Headband Assembly	-	-	1	1
	63993-000	Headband Assembly	1	1	-	-
16	63575-000	Cushion, Headband	2	2	2	2
17	63997-000	Headpad Assembly, Pivot Arm	1	1	1	1
18	63563-000	Headpad Assembly, Right	1	1	1	1
19	51845-004	Screw, No. 2-56 x 5/16	4	4	-	-
20	52188-004	Nut, Hex	4	4	-	-
21	50014-009	Washer, Lock, No. 2	4	4	-	-
22	63998-000	Washer, Nylon	8	8	-	-
23	64003-000	Glider	2	2	-	-
24	63994-000	Housing, Headband Spring Retainer	4	4	-	-
25	63556-000	Spring Assembly, Headband	2	2	-	-
26	63124-023	Foam	1	1	1	1
27	59798-010	Access Hole Cover, Black	1	1	1	1

64000 AZ  
63993 D

\* Only the Headband Assembly for the -000 and -001 headsets is serviceable.

## 23-50-05

## MODEL 5x5® PRO III SERIES HEADSETS

### 64000-100, -101, -102, and -103 Headsets

Item	Part No.	Description	Quantity, 64000-			
			100	101	102	103
1	51845-037	Screw, No. 4-40 x 3/16	1	1	1	1
2	50014-002	Washer, Lock	-	1	-	-
3	64001-013	Clip, Headband/Eyeglass	1	-	-	-
	64001-014	Clip, Headband/Eyeglass	-	1	-	-
	64001-015	Clip, Headband/Eyeglass	-	-	1	-
	64001-016	Clip, Headband/Eyeglass	-	-	-	1
4	56016-004	Screw, No. 0-80 x 3/16	3	3	3	3
5	63096-000	Sleeve, Threaded	3	3	3	3
6	53850-000	Nut, Square, No. 4-40	1	1	1	1
7	63977-000	Receiver Assembly	1	-	1	1
	63977-001	Receiver Assembly	-	1	-	-
8	35629-009	Eartip Assembly	1	1	1	1
9	800126-000	Microphone Assembly, Boom	1	-	1	1
	800126-002	Microphone Assembly, Boom	-	1	-	-
10	63097-002	Clip Assembly, Clothing	1	2	1	1
11	70413-001	Y Cord Assembly	1	-	-	-
	70413-000	Y Cord Assembly	-	1	-	-
	64249-000	Cord Assembly	-	-	1	-
	63988-016	Cord Assembly	-	-	-	1
12	600019-000	Amplifier Assembly	1	1	1	1
13	63976-007	Housing, Receiver/Amplifier, Top	1	1	-	-
	63976-006	Housing, Receiver/Amplifier, Top	-	-	1	1
14	63975-002	Housing, Receiver/Amplifier, Bottom	-	-	1	1
	63975-004	Housing, Receiver/Amplifier, Bottom	1	1	-	-
15*	63993-001	Headband Assembly	-	-	1	1
	63993-000	Headband Assembly	1	1	-	-
16	63575-000	Cushion, Headband	2	2	2	2
17	63997-000	Headpad Assembly, Pivot Arm	1	1	1	1
18	63563-000	Headpad Assembly, Right	1	1	1	1
19	51845-004	Screw, No. 2-56 x 5/16	4	4	-	-
20	52188-004	Nut, Hex	4	4	-	-
21	50014-009	Washer, Lock, No. 2	4	4	-	-
22	63998-000	Washer, Nylon	8	8	-	-
23	64003-000	Glider	2	2	-	-
24	63994-000	Housing, Headband Spring Retainer	4	4	-	-
25	63556-000	Spring Assembly, Headband	2	2	-	-
26	63124-023	Foam	1	1	1	1
27	59798-010	Access Hole Cover, Black	1	1	1	1

64000 AZ  
63993 D

\* Only the Headband Assembly for the -100 and -101 headsets is serviceable.

## 23-50-05

## MODEL 5x5® PRO III SERIES HEADSETS

### 3. ELECTRICAL ADJUSTMENTS

#### A. Microphone/Amplifier Sensitivity Check

- (1) Construct a 470 ohm, 12 Vdc loading network as illustrated in figure 5; connect to microphone plug. (Reference figure 6a-6d for appropriate plug wiring diagram.)
- (2) Position the microphone 1/4 inch (6 mm) above the output port of an artificial voice.
- (3) Connect an audio frequency oscillator to the artificial voice; adjust for an output of 114 dB SPL (0 dB = 20  $\mu$ Pa) at 1 kHz.
- (4) The output, as measured with a vtvm connected across the 150 ohm resistor in the loading network should be 400 millivolts RMS  $\pm$  3 dB.

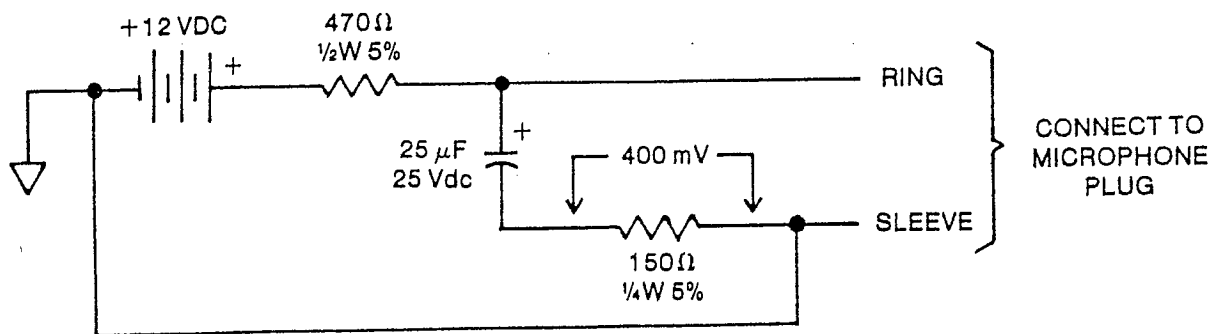

LOADING NETWORK  
FIGURE 5

#### B. Microphone Sensitivity Attenuation (Units with Hybrid Amplifier Assembly) Reference Figures 6a-6d

- (1) Follow disassembly sequence as described in paragraph 2, part A.
- (2) Locate jumper wires connected between pins 2 and 3, and pins 3 and 4 of the Hybrid Amplifier Assembly (see figure 6 for pin numbers).
- (3) To decrease sensitivity 3 dB, clip only the amplifier jumper wire connected between pins 2 and 3.
- (4) To decrease sensitivity 6 dB, clip only the amplifier jumper wire connected between pins 3 and 4.

#### NOTE

For amplifier to operate, one jumper must always remain intact.

#### CAUTION

If reinstallation of a jumper wire is necessary, use only a pencil tip soldering iron rated at 25 watts or less, and SN62 silver bearing solder. Failure to comply will result in permanent damage to the amplifier hybrid.

#### NOTE

The Hybrid Amplifier Assembly is usually factory connected for maximum gain.

## 23-50-05

**MODEL 5x5® PRO III SERIES HEADSETS****C. Microphone Sensitivity Attenuation****(Units with Adjustment Potentiometer and Access Hole)**

- (1) Remove the Headband/Eyeglass Clip (figure 4, item 3) and the Access Hole Cover (item 27).
- (2) Insert a flat-blade jewelers screwdriver through the access hole.
- (3) To increase sensitivity, rotate the trimmer in the clockwise direction.
- (4) To decrease sensitivity, rotate the trimmer in the counter-clockwise direction.

**NOTE**

The trimmer does not have a stop; therefore, it is possible to be at maximum sensitivity and with a very slight clockwise rotation to be at minimum sensitivity.

- (5) Install a new Access Hole Cover when finished.

## MODEL 5x5® PRO III SERIES HEADSETS

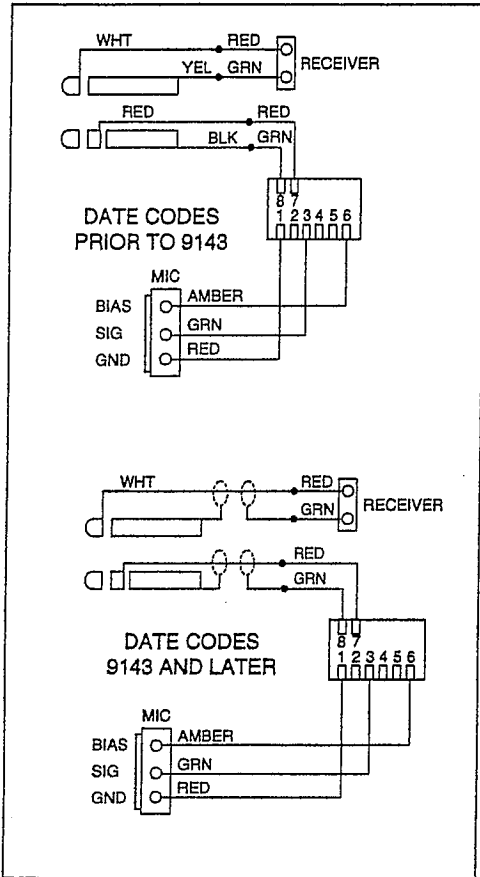

-000 and -100 Headsets  
(a)

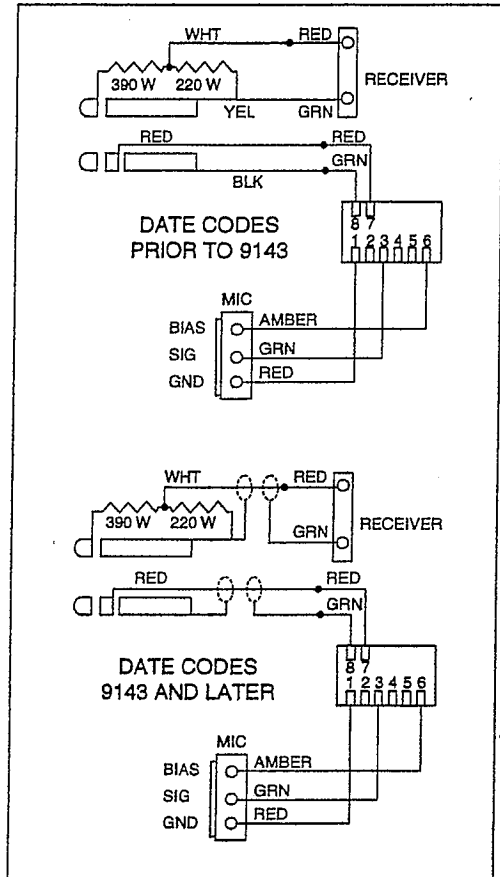

-001 and -101 Headsets  
(b)

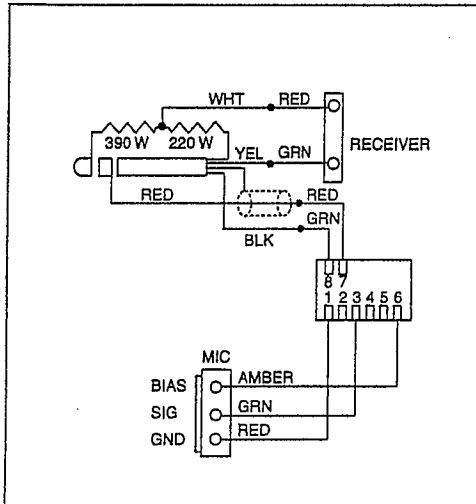

-002 and -102 Headsets  
(c)

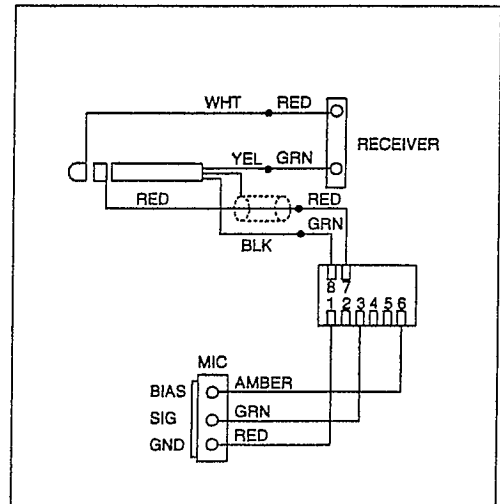

-003 and -103 Headsets  
(d)

WIRING DIAGRAMS  
FIGURE 6

23-50-05



## MODEL 5x5® PRO III SERIES HEADSETS

### 4. TROUBLESHOOTING CHART

	Check Microphone and/or Rcvr Plug	Check Microphone and/or Rcvr Plug	Check Amplifier	Check Cordage	Check Boom/Mic Assembly	Check Ear Tip Assembly	Check Amplifier Sensitivity	Check Receiver	Check Amplifier Board Terminals
Microphone Inoperative	●	●	●	●		●			
Microphone Intermittent	●	●	●	●		●			
Distorted Microphone Signal		●		●		●		●	
Receiver Inoperative		●	●		●		●		
Receiver Intermittent		●	●		●		●		
Distorted Receiver Signal					●		●		
Microphone Level Cannot Be Adjusted Properly With Transceiver		●		●		●		●	